

SCHEDA TECNICA



SERRATURA UNIVERSALE A 2 ESTRAZIONI 165631 OMR



Ø	L	CODICE	NOTE
19	13	165625	90° oraria, 1 estrazione
19	13	165585	90° oraria, 2 estrazioni
19	13	165626	90° antioraria, 1 estrazione
19	13	160090	180°, 2 estrazioni
19	16	165570	90° oraria, 1 estrazione
19	16	165572	90° antioraria, 2 estrazioni
19	16	165571	90° + 90°, 1 estrazione centrale
19	16	165573	180°, 2 estrazioni
19	20	162350	90° oraria, 1 estrazione
19	20	165540	90° antioraria, 1 estrazione
19	20	165580	90° oraria, 2 estrazioni
19	20	162300	180°, 2 estrazioni
19	25	165632	90° oraria, 1 estrazione
19	25	165633	90° antioraria, 1 estrazione
19	25	165631	180°, 2 estrazioni
19	30	163425	180°, 2 estrazioni

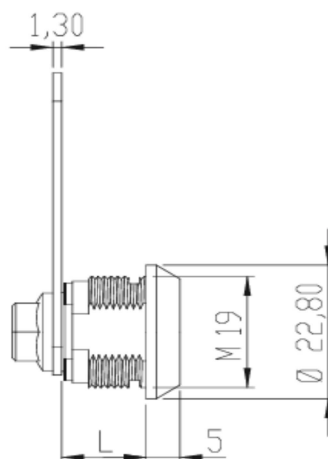
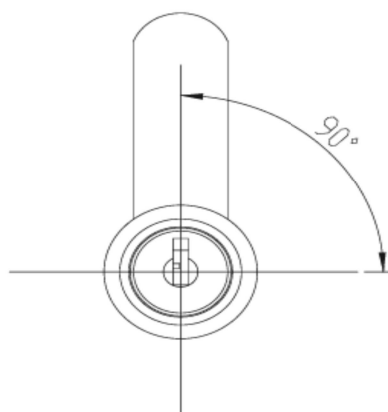

Mostrina per anta in vetro



MPIA04850 anta singola
MPIA04852 anta doppia

Maniglia



SMAN04903